



Preparing for Assembly

Initial Preparations: Prior to assembly, carefully remove all packaging. Place a clean carpet or a piece of cardboard on the floor to prevent scratches or damage to the components. It's important to loosely fit the nuts and bolts during the initial stages of assembly, and only fully tighten them once the entire structure is assembled.

Assembly Steps

Step 1: Bracket Frame and Top Panel

Attach the bracket frame to the top panel using bolts and nuts. Ensure they are securely in place but not fully tightened, as shown in the illustrations below.

Step 2: Legs Installation

Fix the legs to the top panel and bracket frame using the provided bolts and nuts. Again, leave these loosely fitted for now.

Step 3: Bottom Shelf Attachment

Secure the bottom shelf to the legs using bolts and nuts, as depicted below. Do not fully tighten these components at this stage.

Step 4: Side Shelves, Casters, and Handle

Install the side shelves, hooks, casters, and handle to the legs. Use bolts, washers, spring washers, and nuts for this purpose. Adjust them to their correct positions, and then fully tighten all components. Note that the casters with brakes should be installed on the front legs.

Step 5: Countertop Installation

Place the countertop onto the stand using bolts, washers, spring washers, and nuts. Adjust it to the correct position and then tighten it securely. Next, insert the chimney pipe and properly affix the cap, as illustrated below.

Special Warning for Countertop Installation

Handling the Countertop: The countertop is very heavy. Extend the handles before lifting. It is recommended to have four strong individuals assist in lifting and positioning the countertop on the stand. Be cautious and deliberate in your movements. Safety Precautions: Ensure that the casters with brakes are locked while installing the countertop. To protect the stainless steel finish, especially the paint, from scratches or damage, lay a piece of cardboard on the stand during the positioning and adjustment of the countertop.

Image 1

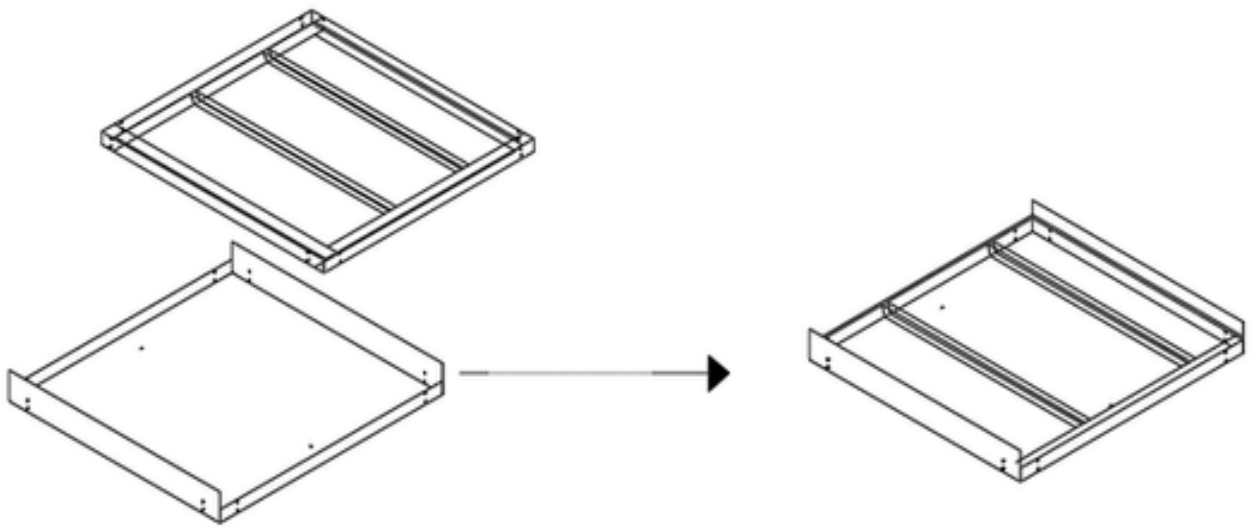

Image 2

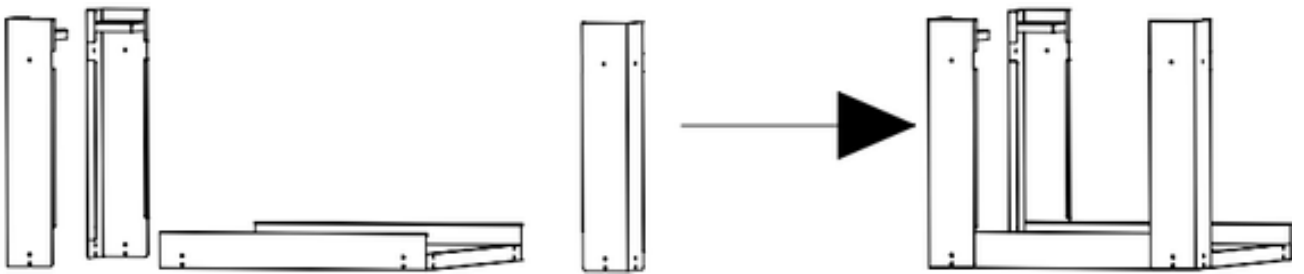

Image 3

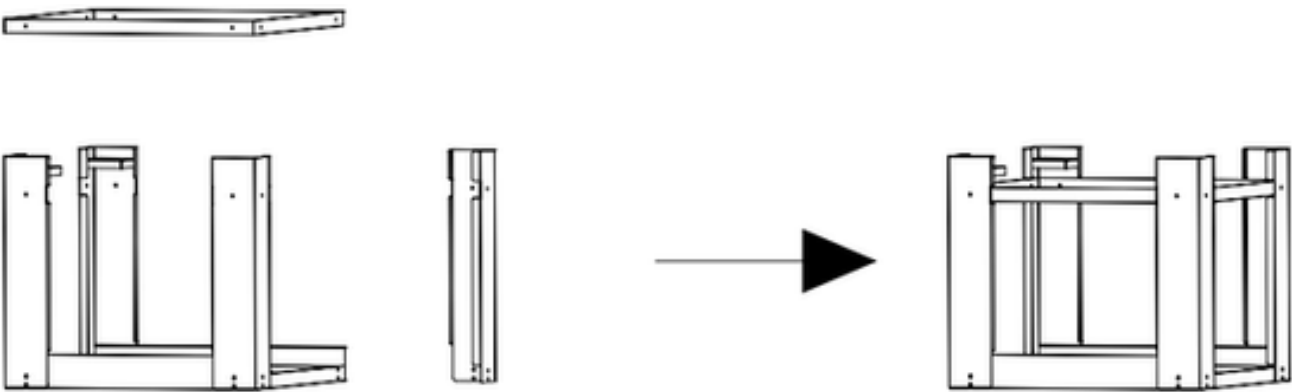

Image 4

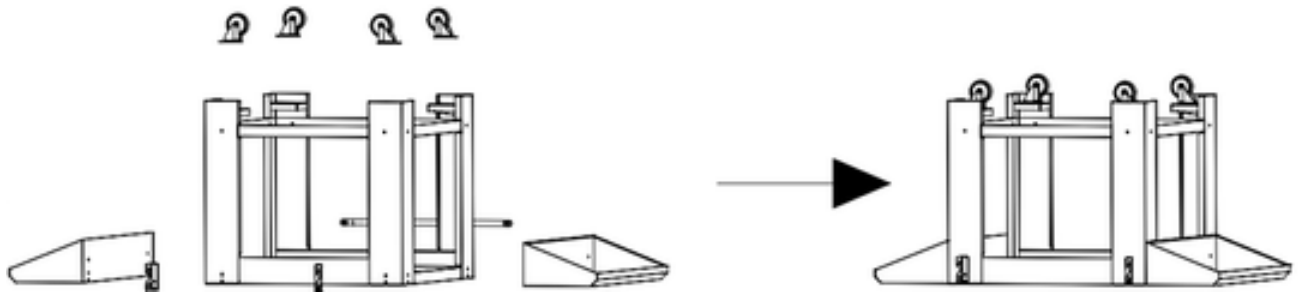

Image 5

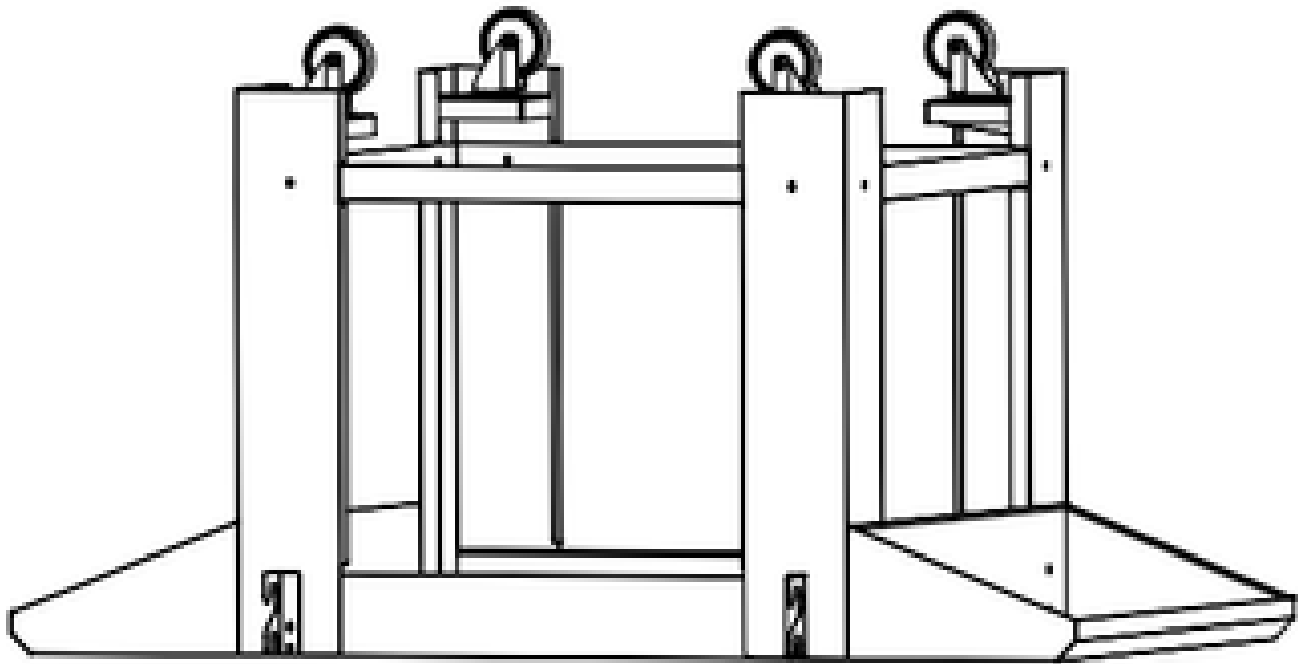

Image 6

